

Product Brief

made assembles high quality RoHS compliant LED modules to customer specifications. Any LED may be specified. Class 2 modules are CSA recognized for dry and damp locations. Conformal coating and end of line assembly verification. LUX, CCT, CRI, Voltage, Current, Chromaticity (X,Y) & (u,v) are available options.

Key Applications

LFT	Industrial
LED Panel	Commercial Indoor
Troffer Retrofit	Channel
High Bay	



Features & Benefits

- High Efficacy, Long Life
- Industry Standard Mechanical Attributes
- Optimized for Industry Standard Power Supplies
- 3 SDCM
- RoHS Compliant

Environmental

Min. Ambient Operating Temp: -22°F , -30°C
Max Board Temp: 185°F , 90°C

Table 1: High Density

CCT	Min. CRI	Dimension (mm)	Typ. FLUX (lm)	LPW	Vf (V)	IF (mA)		Ordering Code
			IF=300mA, Tj=25C		Typ.	Typ.	Max.	
2700K	90	280x20x6.35	1660	139	40.04	300	480	S2820D28C480F9N27CRM281H6A
3000K			1738	145				S2820D28C480F9N30CRM281H6A
3500K			1797	150				S2820D28C480F9N35CRM281H6A
4000K			1848	154				S2820D28C480F9N40CRM281H6A
5000K			1848	154				S2820D28C480F9N50CRM281H6A

Table 2: Low Density

CCT	Min. CRI	Dimension (mm)	Typ. FLUX (lm)	LPW	Vf (V)	IF (mA)		Ordering Code
			IF=150mA, Tj=25C		Typ.	Typ.	Max.	
2700K	90	280x20x6.35	830	139	40.04	150	240	S2820D14C240F9N27CRM281H6A
3000K			869	145				S2820D14C240F9N30CRM281H6A
3500K			898	150				S2820D14C240F9N35CRM281H6A
4000K			924	154				S2820D14C240F9N40CRM281H6A
5000K			924	154				S2820D14C240F9N50CRM281H6A

Data Graph 1: High Density

Typical Module Output and Efficacy vs. Drive Current at 45°C

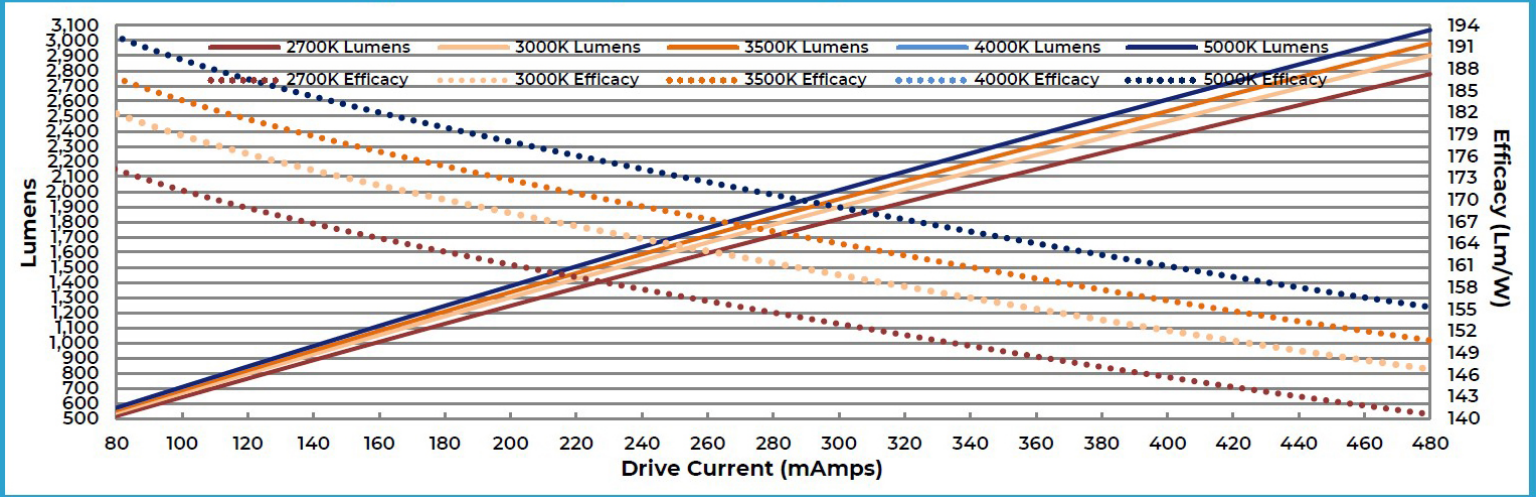

Data Graph 2: Low Density

Typical Module Output and Efficacy vs. Drive Current at 45°C

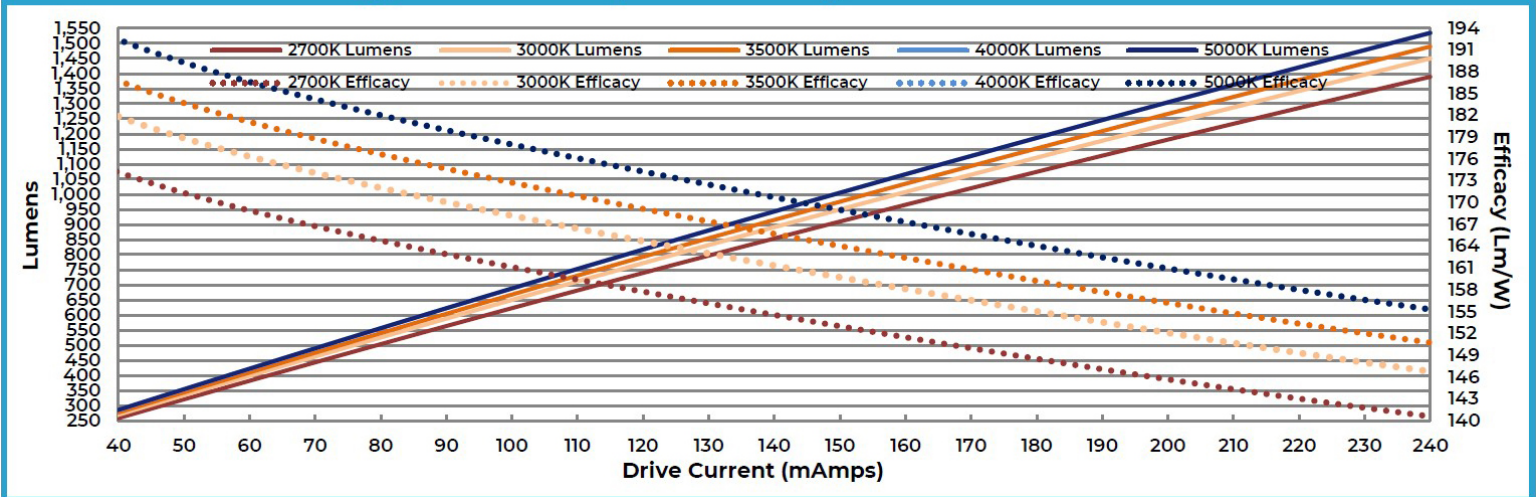

Customization Capabilities

In-house capabilities to quick-turn customized board layout. Available customizations include, but are not limited to:

- PCB width, length and/or thickness
- Positioning and/or size of the mounting holes
- LED count, string configuration
- Connector position
- PCB material
- Color of solder mask

* Depending on the extent of your modification, a layout/tooling NRE may apply.

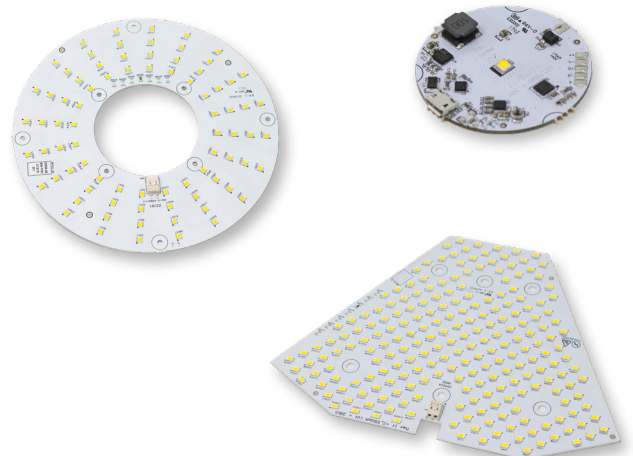

Mechanical Dimensions

Image 1. Mechanical Drawing

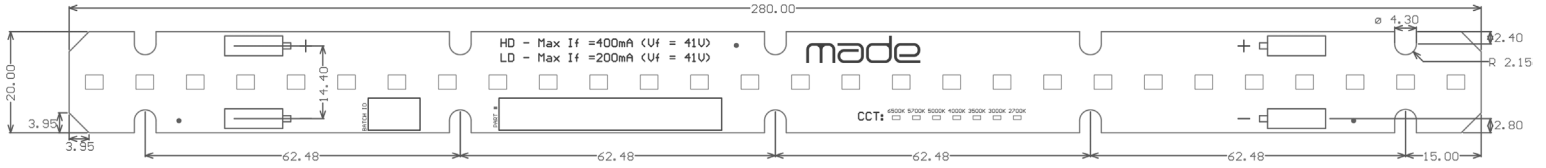

Marking References

Figure 1. Marking Resistor



Figure 2. Laser Markings

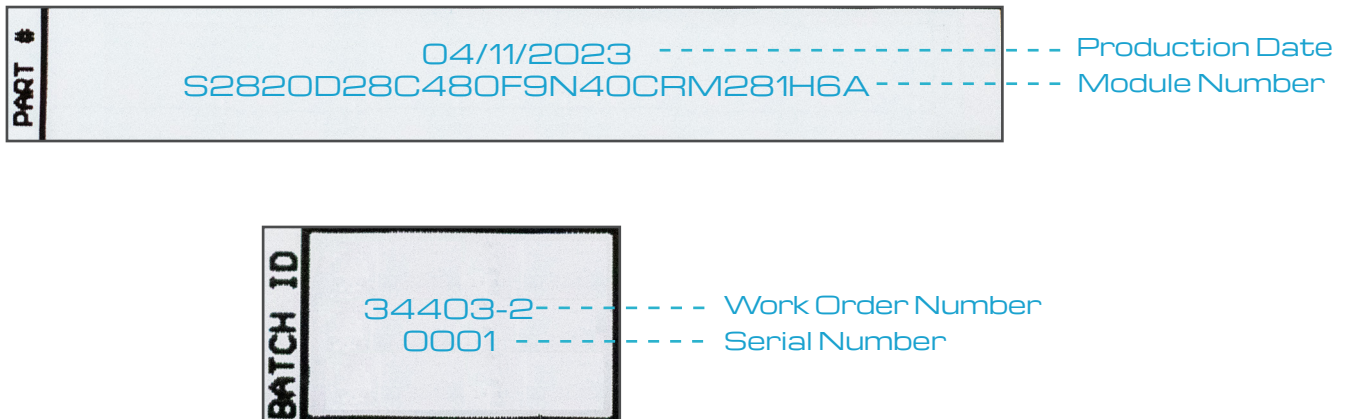

Notes :

- 1) All dimensions are in millimeters
- 2) Drawings and Figures not to Scale
- 3) Module Thickness: 1.6mm

Wire Diagrams

Figure 3. Parallel Wiring - Physical Connection

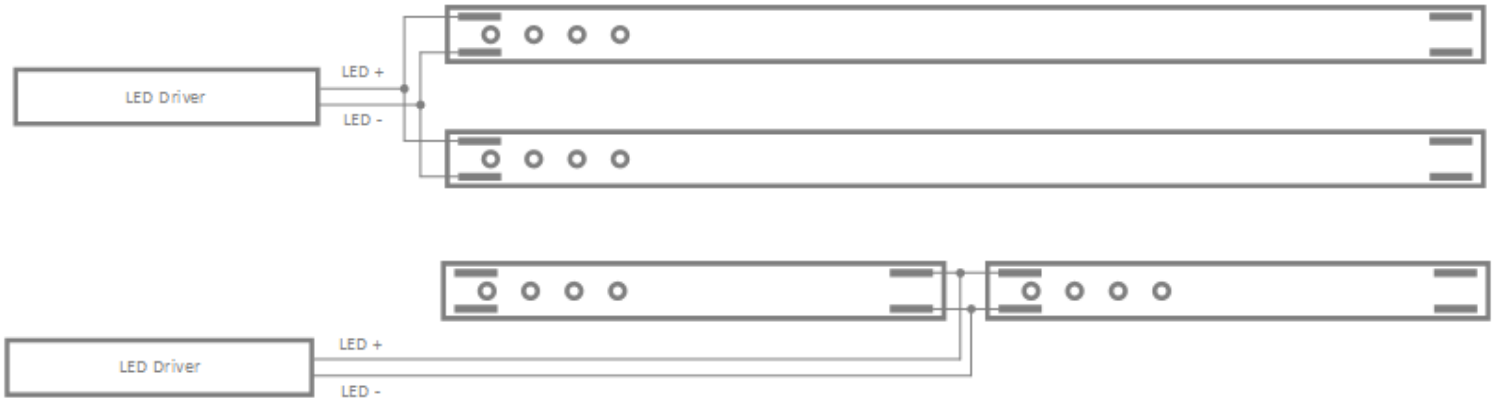

Figure 4. Series Wiring - Physical Connection



Notes :

All wiring configurations above connect the LED modules in parallel electrically.

Table 3 : Wire Specifications

Wire Specifications	
Connector Type	Poke-in Terminal
Wire Type	Solid or Fine-Stranded Conductor
Strip Length	0.275-0.350 in. (7-9mm)
Wire Size	18-22 AWG

Packing

Table 4: Packaging Dimensions

Tray			Box		
Size (mm)	Module Qty (EA)	Material	Size (mm)	Tray Qty (EA)	Module Qty (EA)
325x197x38	20	Anti-static Foam	686x224x229	10 Trays	200

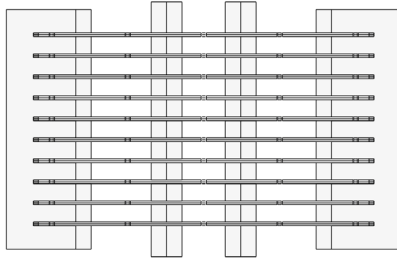

20pcs LED Module per Tray

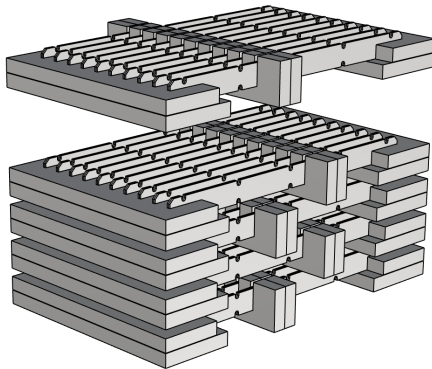

5pcs Tray with LED Module

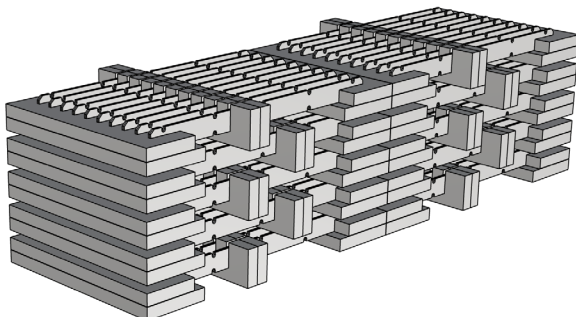

5pcs Tray go into a 27x9x9 Box

Figure 5. Box Label*

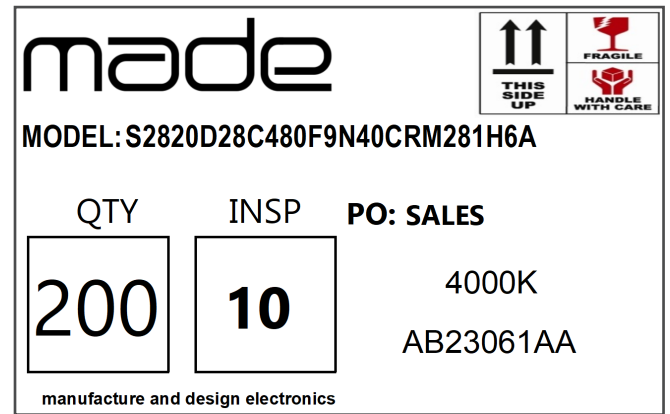

*Customizable per Customer Specifications

Conditions of Acceptable Usage

This component has been judged on the basis of the required spacing distances in the Standard for LED Equipment for Use in Lighting Products.

- 1) The LED modules are intended for connection to a constant current, Class 2 power supply. When the arrays are connected and used with power supplies other than class 2, the need for an additional evaluation shall be considered in the end use product investigation.
- 2) The LED modules shall be installed in compliance with the mounting, spacing, casualty, and the segregation requirements applicable to the ultimate application.
- 3) The LED modules were not subjected to the Normal Temperature Test. A Temperature Test shall be conducted in the end product with considerations for the following components, their ratings, and LED-to-LED spacing:
 - Printed Wiring Board – 105°C
 - Connectors – 105°C
- 4) The LED modules are intended for use in dry and damp locations when connected to a Class 2 power supply. Use in other than dry and damp locations powered by a Class 2 power supply shall be evaluated to the end use application.
- 5) All models shall be marked with any voltage and current rating that doesn't exceed the maximum ratings in the ELECTRICAL RATINGS table of this report. All modules are to be used within their marked ratings.
- 6) Electrical over-stress may result in permanent damage to the device if the device is subjected to a current or voltage beyond the maximum specification limits cited.
- 7) Events causing over-stress must be prevented through the use of proper surge protection circuits or voltage limiting devices.

Precaution for Use

- 1) Do not touch the optic with bare hands. Use cotton gloves to prevent oils from contaminating the optics.
- 2) Do not flex or bend the PCB.
- 3) The circuit board operates a high voltage, do not touch any of the circuit board, components or terminals with body or metal while circuit is active.
- 4) Please do not assemble in conditions of high moisture and/or oxidizing gas such as Cl, H₂S, N₂, H₂O, SO₂, NO_x, etc.
- 5) Please do not make any modification to the module.
- 6) Please be cautious when soldering to board so as not to create a short between different trace patterns.

Handling with Regards to Static Electricity

- 1) Please handle using equipment that prevents static electricity and ESD ("electro-static discharge").
- 2) Do not touch unless personal ESD protection is used, such as wrist/heel straps, anti-static shoes, or anti-static clothes.
- 3) Humidity control is recommended to prevent dry environment.

Handling with Regards to VOCs

- 1) This device is not intended to be stored, transported, installed, tested, or used in the vicinity of adhesives or other materials as the outgas from these materials can damage the silicone encapsulating LEDs.
- 2) LEDs may appear discolored when exposed to VOCs, resulting in significant loss of light output.
- 3) VOCs are often present in the facilities, environment or installation, packaging, fixture or construction materials.

Storage Before Use

- 1) Do not impact or place pressure on this product because even a small amount of pressure can damage the product.
- 2) The product should also not be placed in high temperatures, high humidity or direct sunlight. The device is sensitive to these conditions.
- 3) When storing devices for a long period of time before usage, please following these guidelines.
 - The device should be stored in the anti-static foam trays and fingers they were shipped in.
 - Store in a cool dry place preventing air and moisture from being present.

Company Information

Published by made @ 2023 All rights Reserved.

Manufacture and Design Electronics (“made”) LLC and Made Systems LLC collectively are global providers of custom Level 2 modules and other electronic services and devices for the general lighting, industrial, appliance, signage, medical, agriculture, and automotive industries. made is known for its unique culture that has proven to attract and retain creative driven minds. Since its founding in 2010, made has provided over 2000 unique circuit board designs into the stream of commerce and maintains its legacy by continuing to support the innovation aims of Tier 1 and OEMs.

Legal Disclaimer

Information in this document is provided in connection with made’s products. With respect to any examples given herein, any typical values stated and/or any information regarding the device, made hereby disclaims any and all warranties and liabilities of any kind including without limitation, warranties of non-infringement of intellectual property rights of any third party. The appearance and specifications of the product can be changed to improve quality and/or performance without notice.

Table 5. Revision History

Revision	Date	Remarks
Rev 1.1	04.11.2023	Initial Design Release